



# COMPTOIRS ET VITRINES PIZZA

- Le comptoir pour pizza est composé d'une table réfrigérée, un caisson-tiroir neutre pour les patons à pizza, un plan de travail en granit pour la préparation et une vitrine réfrigérées pour les ingrédients

## TABLE REFRIGEREE:

- Construction entièrement en acier inox AISI 304 18/10
- Angles intérieurs arrondis et fond moulé
- Epaisseur d'isolation de 50 mm en polyuréthane expensé à haute densité sans CFC et HCFC
- Supports latéraux pour glissière et clayette facilement démontables sans outils
- Groupe frigorifique ventilé tropicalisé (+43°C)
- Modèles prédisposés avec ou sans unités de condensation à distance livrée par le fournisseur
- Modèles split avec groupe frigorifique et tuyaux préchargés déjà prêts pour l'installation
- Gaz réfrigérant écologique R404a
- Panneau de contrôle électronique
- Dégivrage automatique
- Evaporation automatique de l'eau de condensation
- Aspiration et expulsion de l'air de condensation sur la partie frontale du groupe
- Tableau de bord extérieur fixé par charnières pour l'entretien ordinaire et le nettoyage périodique de l'unité de condensation
- Portes auto-fermantes avec joints magnétiques remplaçables et facilement substituables
- Pieds en inox réglables en hauteur

## VITRINE REFRIGEREE:

- Construction entièrement en acier inox AISI 304 18/10
- Angles intérieurs arrondis
- Isolation en polyuréthane
- Isolation en polyuréthane expensé à haute densité sans CFC et HCFC
- Groupe frigorifique statique
- Panneau de contrôle électronique
- Protection supérieure en vitre plat ou bombé

En dotation: n 1 clayette plastifiée pour chaque porte

Les prix de comptoirs pizza complets, des tables, des vitrines et caissons tiroirs ne comprennent pas les conteneurs 60 x 40 et bacs gastronomes.

- Emballage en carton inclus



## COMPTOIRS POUR PIZZERIA

Acier inox 18/10 AISI 304

**Réf.**                      **Modèle**                      **Temp °**                      **vitre bombée**                      **vitre plate**

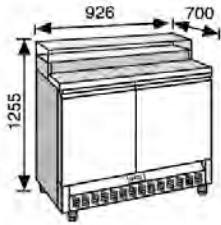

TB 043A	GNR PZ 92	0°+10°C		X
---------	-----------	---------	--	---

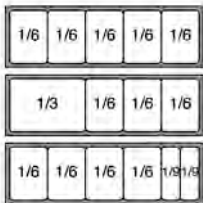

KIT 61	Bacs en inox			X
KIT 62	Bacs en inox			
KIT 63	Bacs en inox			

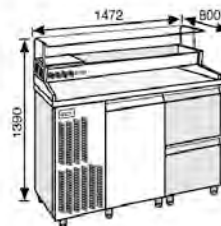

TB045B	BNR PZ 92 VTR1C-8C	-2+10°C	X	X
TB047B	BNR PZ 92 VTR1P-8C	-2+10°C	X	X
TB046B	BNR PZ 92 VTR6C-8C	-2+10°C	X	X
TB048B	BNR PZ 92 VTR6P-8C	-2+10°C	X	X



TB045C	BNR PZ 92 VTR1C-7C	-2+10°C	X	
TB047C	BNR PZ 92 VTR1P-7C	-2+10°C		X
TB046C	BNR PZ 92 VTR6C-7C	-2+10°C	X	
TB048C	BNR PZ 92 VTR6P-7C	-2+10°C	X	X

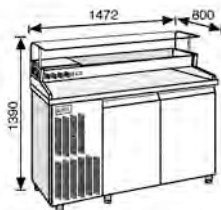

TB045F	BNR PZ 145 VTR1C	-2+10°C	X	
TB047F	BNR PZ 145 VTR1P	-2+10°C		X
TB046F	BNR PZ 145 VTR6C	-2+10°C	X	
TB048F	BNR PZ 145 VTR6P	-2+10°C		X

## COMPTOIRS POUR PIZZERIA

Acier inox 18/10 AISI 304

Réf.	Modèle	Temp °	vitre bombée	vitre plate
TB045G	BNR PZ 145 VTR3C-8C	-2+10°C	X	
TB047G	BNR PZ 145 VTR3P-8C	-2+10°C		X
TB046G	BNR PZ 145 VTR8C-8C	-2+10°C	X	
TB048G	BNR PZ 145 VTR8P-8C	-2+10°C		X



TB045H	BNR PZ 145 VTR3C-7C	-2+10°C	X	
TB047H	BNR PZ 145 VTR3P-7C	-2+10°C		X
TB046H	BNR PZ 145 VTR8C-7C	-2+10°C	X	
TB048H	BNR PZ 145 VTR8P-7C	-2+10°C		X



TB045K	BNR PZ 198 VTR3C	-2+10°C	X	X
TB047K	BNR PZ 198 VTR3P	-2+10°C	X	X
TB046K	BNR PZ 198 VTR8C	-2+10°C	X	X
TB048K	BNR PZ 198 VTR8P	-2+10°C	X	X

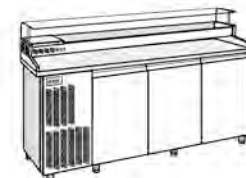



## COMPTOIRS POUR PIZZERIA

Acier inox 18/10 AISI 304

**Réf.**                      **Modèle**                      **Temp °**                      **vitre bombée**                      **vitre plate**

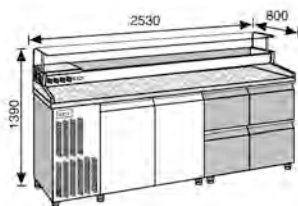

TB045I	BNR PZ 145 VTR5C-16C	-2+10°C	x	
TB047I	BNR PZ 145 VTR5P-16C	-2+10°C		x
TB046I	BNR PZ 145 VTR10C-16C	-2+10°C	x	
TB048I	BNR PZ 145 VTR10P-16C	-2+10°C		x

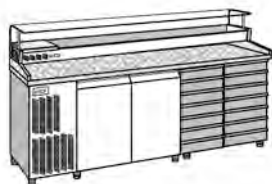

TB045J	BNR PZ 145 VTR5C-14C	-2+10°C	x	
TB047J	BNR PZ 145 VTR5P-14C	-2+10°C		x
TB046J	BNR PZ 145 VTR10C-14C	-2+10°C	x	
TB048J	BNR PZ 145 VTR10P-14C	-2+10°C		x

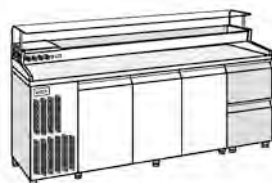

TB045L	BNR PZ 198 VTR5C-8C	-2+10°C	x	
TB047L	BNR PZ 198 VTR5P-8C	-2+10°C		x
TB046L	BNR PZ 198 VTR10C-8C	-2+10°C	x	
TB048L	BNR PZ 198 VTR10P-8C	-2+10°C		x

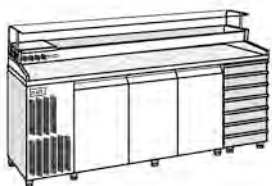

TB045M	BNR PZ 198 VTR5C-7C	-2+10°C	x	
TB047M	BNR PZ 198 VTR5P-7C	-2+10°C		x
TB046M	BNR PZ 198 VTR10C-7C	-2+10°C	x	
TB048M	BNR PZ 198 VTR10P-7C	-2+10°C		x

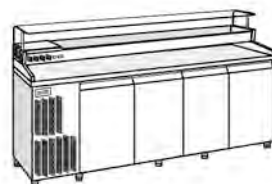

TB045P	BNR PZ 251 VTR5C	-2+10°C	x	
TB047P	BNR PZ 251 VTR5P	-2+10°C		x
TB046P	BNR PZ 251 VTR10C	-2+10°C	x	
TB048P	BNR PZ 251 VTR10P	-2+10°C		x

## COMPTOIRS PRÉDISPOSES POUR PIZZERIA

Acier inox 18/10 AISI 304

Réf.	Modèle	Temp °	vitre bombée	vitre plate
TH045G	BNP PZ 126 VTR2C-8C	-2+10°C	x	
TH047G	BNP PZ 126 VTR2P-8C	-2+10°C		x
TH046G	BNP PZ 126 VTR7C-8C	-2+10°C	x	
TH048G	BNP PZ 126 VTR7P-8C	-2+10°C		x

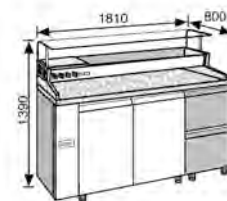

TH045H	BNP PZ 126 VTR2C-7C	-2+10°C	x	
TH047H	BNP PZ 126 VTR2P-7C	-2+10°C		x
TH046H	BNP PZ 126 VTR7C-7C	-2+10°C	x	
TH048H	BNP PZ 126 VTR7P-7C	-2+10°C		x



TH045K	BNP PZ 179 VTR2C	-2+10°C	x	
TH047K	BNP PZ 179 VTR2P	-2+10°C		x
TH046K	BNP PZ 179 VTR7C	-2+10°C	x	
TH048K	BNP PZ 179 VTR7P	-2+10°C		x

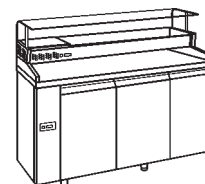

9980	Condensateur pour table prédisposée TNBV à détendeur	-2+10°C		mod 126
9982	Condensateur pour table prédisposée TNBV à détendeur	-2+10°C		mod 179





## COMPTOIRS PRÉDISPOSES POUR PIZZERIA

Acier inox 18/10 AISI 304



Réf.	Modèle	Temp °	vitre bombée	vitre plate
TH045I	BNP PZ 126 VTR4C-16C	-2+10°C	x	
TH047I	BNP PZ 126 VTR4P-16C	-2+10°C		x
TH046I	BNP PZ 126 VTR9C-16C	-2+10°C	x	
TH048I	BNP PZ 126 VTR9P-16C	-2+10°C		x



TH045J	BNP PZ 126 VTR4C-14C	-2+10°C	x	
TH047J	BNP PZ 126 VTR4P-14C	-2+10°C		x
TH046J	BNP PZ 126 VTR9C-14C	-2+10°C	x	
TH048J	BNP PZ 126 VTR9P-14C	-2+10°C		x



TH045L	BNP PZ 179 VTR4C-8C	-2+10°C	x	
TH047L	BNP PZ 179 VTR4P-8C	-2+10°C		x
TH046L	BNP PZ 179 VTR9C-8C	-2+10°C	x	
TH048L	BNP PZ 179 VTR9P-8C	-2+10°C		x

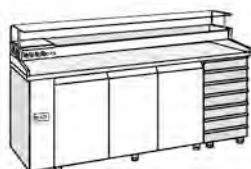

TH045M	BNP PZ 179 VTR4C-7C	-2+10°C	x	
TH047M	BNP PZ 179 VTR4P-7C	-2+10°C		x
TH046M	BNP PZ 179 VTR9C-7C	-2+10°C	x	
TH048M	BNP PZ 179 VTR9P-7C	-2+10°C		x



TH045P	BNP PZ 232 VTR4C	-2+10°C	x	
TH047P	BNP PZ 232 VTR4P	-2+10°C		x
TH046P	BNP PZ 232 VTR9C	-2+10°C	x	
TH048P	BNP PZ 232 VTR9P	-2+10°C		x

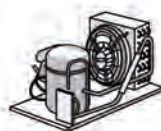

9980	Condensateur pour table prédisposée TNBV à détendeur	-2+10°C		mod 126
9982	Condensateur pour table prédisposée TNBV à détendeur	-2+10°C		mod 179
9984	Condensateur pour table prédisposée TNBV à détendeur	-2+10°C		mod 232

## COMPTOIRS RÉFRIGÉRÉS SPLIT

Acier inox 18/10 AISI 304

Réf.	Modèle	Temp °	vitre bombée	vitre plate
TE045G	BNS PZ 126 VTR2C-8C	-2+10°C	x	
TE047G	BNS PZ 126 VTR2P-8C	-2+10°C		x
TE046G	BNS PZ 126 VTR7C-8C	-2+10°C	x	
TE048G	BNS PZ 126 VTR7P-8C	-2+10°C		x

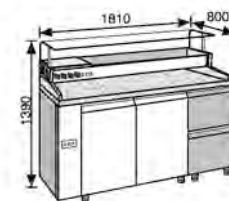

TE045H	BNS PZ 126 VTR2C-7C	-2+10°C	x	
TE047H	BNS PZ 126 VTR2P-7C	-2+10°C		x
TE046H	BNS PZ 126 VTR7C-7C	-2+10°C	x	
TE048H	BNS PZ 126 VTR7P-7C	-2+10°C		x



TE045K	BNP PZ 179 VTR2C	-2+10°C	x	
TE047K	BNP PZ 179 VTR2P	-2+10°C		x
TE046K	BNP PZ 179 VTR7C	-2+10°C	x	
TE048K	BNP PZ 179 VTR7P	-2+10°C		x

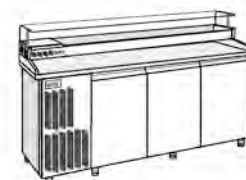



## COMPTOIRS RÉFRIGÉRÉS SPLIT

Acier inox 18/10 AISI 304



Réf.	Modèle	Temp °	vitre bombée	vitre plate
TE045I	BNP PZ 126 VTR4C-16C	-2+10°C	x	
TE047I	BNP PZ 126 VTR4P-16C	-2+10°C		x
TE046I	BNP PZ 126 VTR9C-16C	-2+10°C	x	
TE048I	BNP PZ 126 VTR9P-16C	-2+10°C		x



TE045J	BNP PZ 126 VTR4C-14C	-2+10°C	x	
TE047J	BNP PZ 126 VTR4P-14C	-2+10°C		x
TE046J	BNP PZ 126 VTR9C-14C	-2+10°C	x	
TE048J	BNP PZ 126 VTR9P-14C	-2+10°C		x



TE045L	BNP PZ 179 VTR4C-8C	-2+10°C	x	
TE047L	BNP PZ 179 VTR4P-8C	-2+10°C		x
TE046L	BNP PZ 179 VTR9C-8C	-2+10°C	x	
TE048L	BNP PZ 179 VTR9P-8C	-2+10°C		x



TE045M	BNP PZ 179 VTR4C-7C	-2+10°C	x	
TE047M	BNP PZ 179 VTR4P-7C	-2+10°C		x
TE046M	BNP PZ 179 VTR9C-7C	-2+10°C	x	
TE048M	BNP PZ 179 VTR9P-7C	-2+10°C		x

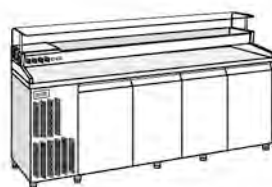

TE045P	BNP PZ 232 VTR4C	-2+10°C	x	
TE047P	BNP PZ 232 VTR4P	-2+10°C		x
TE046P	BNP PZ 232 VTR9C	-2+10°C	x	
TE048P	BNP PZ 232 VTR9P	-2+10°C		x

## VITRINES RÉFRIGÉREES GN POUR PIZZERIA

Acier inox 18/10 AISI 304

**Réf.**                      **Modèle**                      **bombée**   **plate**   **ss vitre**

VA0100	vetrina VTR1 C	X		
VA0200	vetrina VTR1 P		X	
VA0300	vetrina VTR1 S			X

KIT31	bacs inox + couvercles inox		X	
KIT32	bacs inox + couvercles inox		X	
KIT33	bacs inox + couvercles inox		X	

VB0100	vetrina VTR2 C	X		
VB0200	vetrina VTR2 P		X	
VB0300	vetrina VTR2 S			X

KIT34	bacs inox + couvercles inox		X	
KIT35	bacs inox + couvercles inox		X	
KIT36	bacs inox + couvercles inox		X	

VC0100	vetrina VTR3 C	X		
VC0200	vetrina VTR3 P		X	
VC0300	vetrina VTR3 S			X

KIT37	bacs inox + couvercles inox		X	
KIT38	bacs inox + couvercles inox		X	
KIT39	bacs inox + couvercles inox		X	

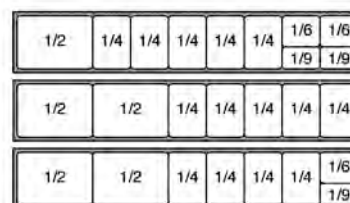
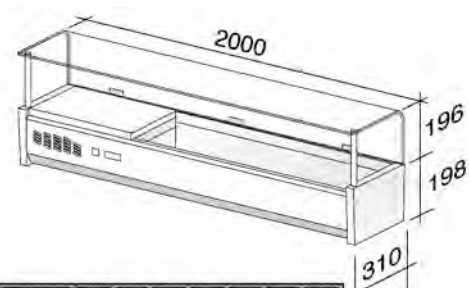
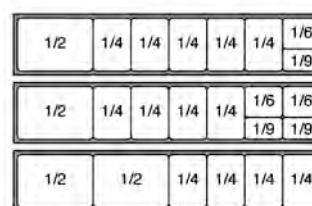
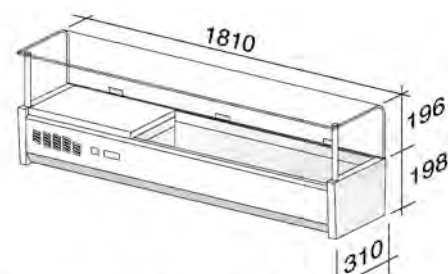
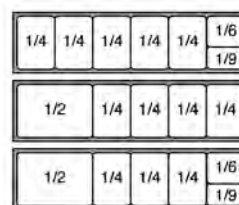
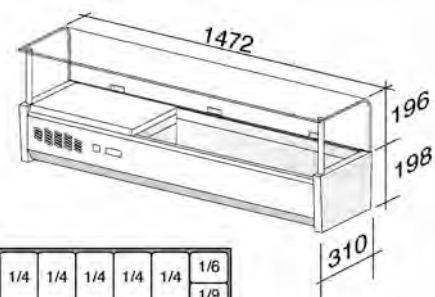



## VITRINES RÉFRIGÉREES GN POUR PIZZERIA

Acier inox 18/10 AISI 304

**Réf.**                      **Modèle**                      **bombée**   **plate**   **ss vitre**

VF0100	vetrina VTR6 C	X		
VF0200	vetrina VTR6 P		X	
VF0300	vetrina VTR6 S			X

KIT46	bacs inox + couvercles inox		X	
KIT47	bacs inox + couvercles inox		X	
KIT48	bacs inox + couvercles inox		X	

VG0100	vetrina VTR7 C	X		
VG0200	vetrina VTR7 P		X	
VG0300	vetrina VTR7 S			X

KIT49	bacs inox + couvercles inox		X	
KIT50	bacs inox + couvercles inox		X	
KIT51	bacs inox + couvercles inox		X	

VH0100	vetrina VTR8 C	X		
VH0200	vetrina VTR8 P		X	
VH0300	vetrina VTR8 S			X

KIT52	bacs inox + couvercles inox		X	
KIT53	bacs inox + couvercles inox		X	
KIT54	bacs inox + couvercles inox		X	

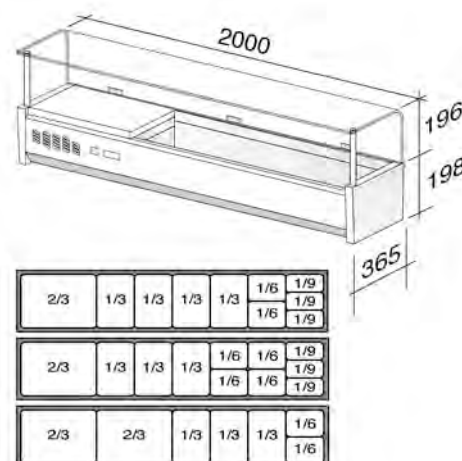
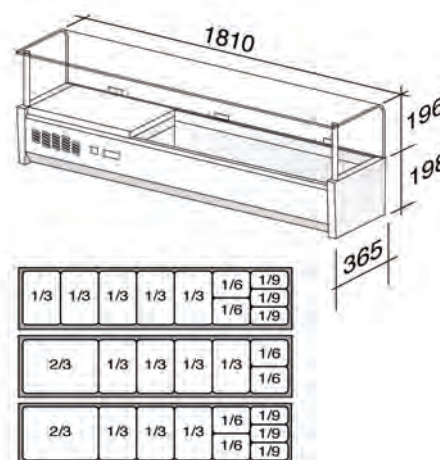
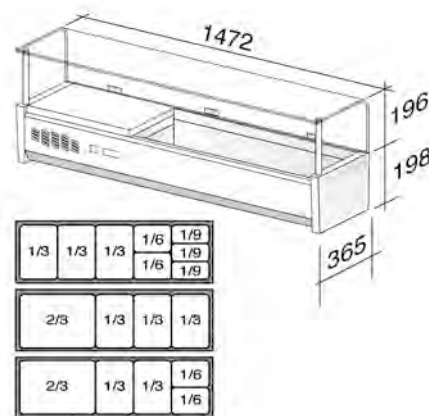





## TABLES RÉFRIGÉREES POUR PIZZERIA

Acier inox 18/10 AISI 304

Réf.	Modèle	Temp °
TB052A	BNR PZ 92	-2+10°C
TB052F	BNR PZ 145	-2+10°C
TB052K	BNR PZ 198	-2+10°C
TB052P	BNR PZ 251	-2+10°C

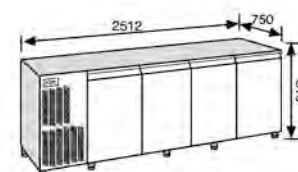
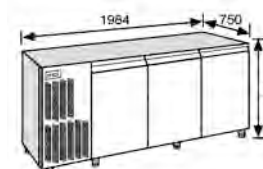
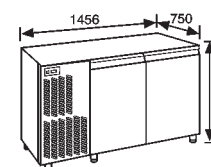
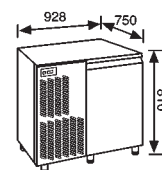



## TABLES PRÉDISPOSÉES POUR PIZZERIA

Acier inox 18/10 AISI 304

Réf.	Modèle	Temp °
------	--------	--------

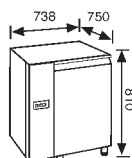

TH052A	BNR PZ 73	-2+10°C
--------	-----------	---------

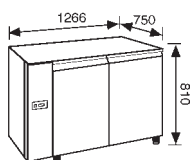

TH052F	BNR PZ 126	-2+10°C
--------	------------	---------

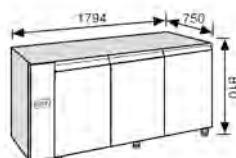

TH052K	BNR PZ 179	-2+10°C
--------	------------	---------

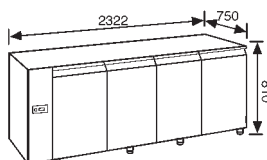

TH052P	BNR PZ 232	-2+10°C
--------	------------	---------

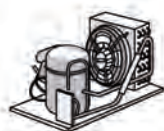

9082	Condensateur pour table prédisposée TNBV à détenteur	mod 73
9980	Condensateur pour table prédisposée TNBV à détenteur	mod 126
9982	Condensateur pour table prédisposée TNBV à détenteur	mod 179
9984	Condensateur pour table prédisposée TNBV à détenteur	mod 232

## TABLES RÉFRIGÉREES POUR PIZZERIA

Acier inox 18/10 AISI 304

Réf.	Modèle	Temp °
TE052A	BNR PZ 73	-2+10°C
TE052F	BNR PZ 126	-2+10°C
TE052K	BNR PZ 179	-2+10°C
TE052P	BNR PZ 232	-2+10°C

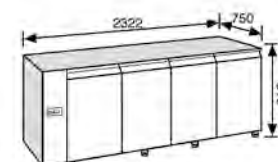
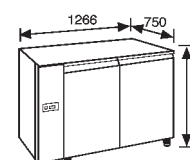



## DESSUS EN GRANIT POUR PIZZERIA

Acier inox 18/10 AISI 304

Réf.	Modèle	Dimension
------	--------	-----------

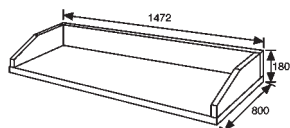

13831	Dessus avec relèvement derrière	800 x1742 x180h
-------	---------------------------------	-----------------

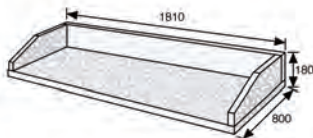

13832	Dessus avec relèvement derrière	800 x1810 x180h
-------	---------------------------------	-----------------

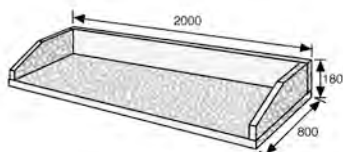

13833	Dessus avec relèvement derrière	800 x2000 x180h
-------	---------------------------------	-----------------

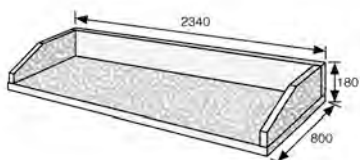

13834	Dessus avec relèvement derrière	800 x2340 x180h
-------	---------------------------------	-----------------

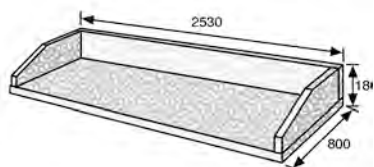

13835	Dessus avec relèvement derrière	800 x2530 x180h
-------	---------------------------------	-----------------

## CAISSONS TIROIRS NON RÉFRIGÉRÉS POUR CONTENEURS PIZZA 60X40

Acier inox 18/10 AISI 304

**Réf.** **Modèle**

---

13851 8C - 2 tiroirs pour 8 conteneurs Prof.750

---

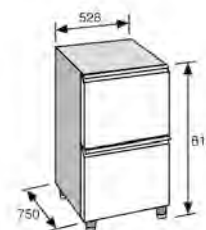

13852 7C - 2 tiroirs pour 7 conteneurs Prof.750

---



13853 16C - 4 tiroirs pour 16 conteneurs Prof.750

---

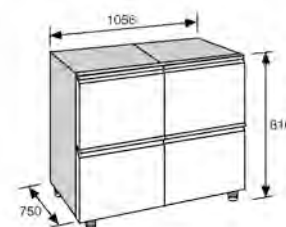

13854 14C - 14 tiroirs pour 14 conteneurs Prof.750

---

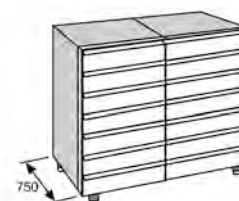



## ACCESSOIRES POUR PIZZA

Réf.	Description	Dim.	table modèle
9528	Clayette plastifiée	400 x 600	BN
9527	Clayette plastifiée	325 x 550	GN1
9531	Clayette inox	400 x 600	BN
9530	Clayette inox	325 x 550	GN1
9599	Paire glissières inox	L 620	BNP
9595	Paire glissières inox	L 570	GN1
9654	Conteneur plastique pour.pizza	400 x 600	
9655	Couvercle pour conteneur.pizza	400 x 600	
9423	Bacs inox gastronomes	325 x 550 x150h	GN 1/1
9425	Bacs inox gastronomes	325 x 354 x150h	GN 2/3
9423	Bacs inox gastronomes	325 x 265 x150h	GN 1/2
9426	Bacs inox gastronomes	325 x 176 x150h	GN 1/3
9450	Bacs inox gastronomes	162 x 265 x150h	GN 1/4
9427	Bacs inox gastronomes	162 x 176 x150h	GN 1/6
9679	Bacs inox gastronomes	108 x 176 x150h	GN 1/9
9648	Couvercles inox gastronomes		GN 1/1
9664	Couvercles inox gastronomes		GN 1/2
9665	Couvercles inox gastronomes		GN 1/2
9666	Couvercles inox gastronomes		GN 1/3
9667	Couvercles inox gastronomes		GN 1/4
9668	Couvercles inox gastronomes		GN 1/6
9680	Couvercles inox gastronomes		GN 1/9
9650	Bacs plastique gastronomes	325 x 550 x150h	GN 1/1
9670	Bacs plastique gastronomes	325 x 365 x150h	GN 2/3
9671	Bacs plastique gastronomes	325 x 176 x150h	GN 1/2
9672	Bacs plastique gastronomes	162 x 265 x150h	GN 1/3
9673	Bacs plastique gastronomes	162 x 176 x150h	GN 1/4
9681	Bacs plastique gastronomes	108 x 176 x100h	GN 1/6



## ACCESSOIRES POUR PIZZA

Réf.	Description	Dim.	table modèle
9651	Couvercle plastique gastronorme		GN1/1
9675	Couvercle plastique gastronorme		GN2/3
9676	Couvercle plastique gastronorme		GN1/3
9677	Couvercle plastique gastronorme		GN1/4
9678	Couvercle plastique gastronorme		GN1/6
9682	Couvercle plastique gastronorme		GN1/9
9658	Chariot extractible pour table à pizza		
9991	Support inox pour bacs GN		VITR 1-2-3-4-5
9992	Support inox pour bacs GN		VITR 6-7-8-9-10

